

NL: Montagehandleiding en veiligheidsvoorschriften – pagina 3
DE: Montageanleitung und Sicherheitsvorschriften – Seite 24
UK: Assembly instruction and safety regulations – page 45
FR: Notice d'assemblage et de sécurité – page 66

Fietsendrager/Fahrradträger/Bike carrier/Porte-vélos

DIAMANT TG

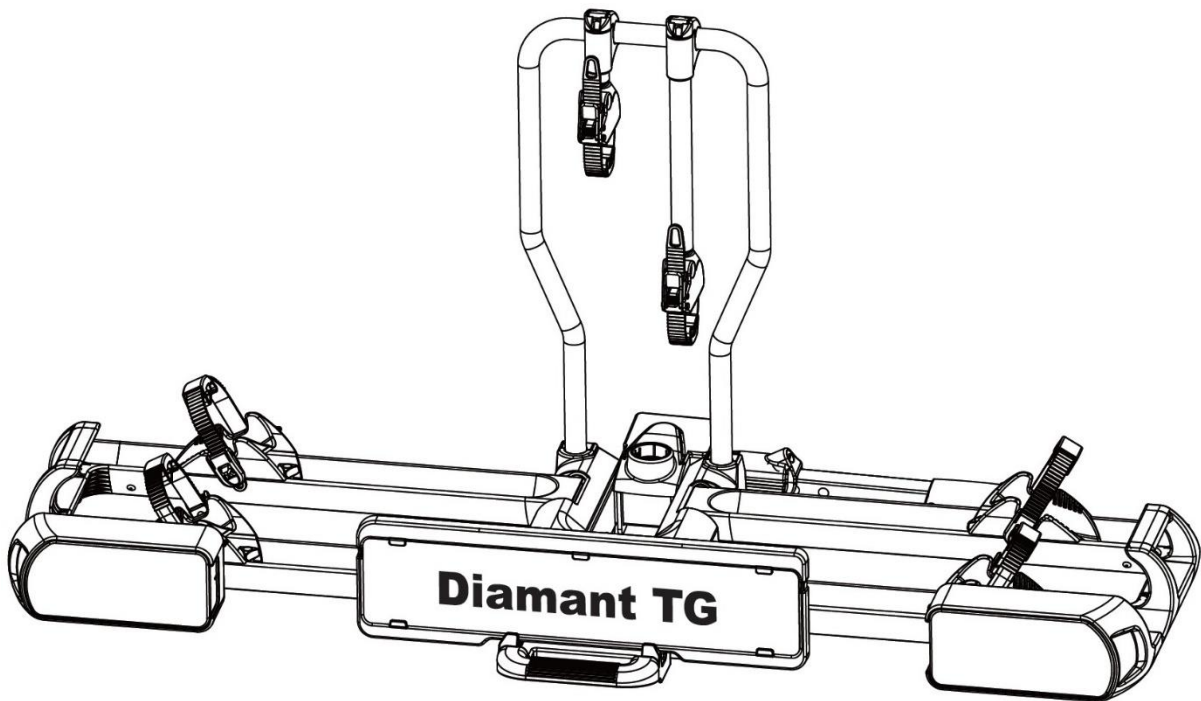

PRO **BIKE CARRIERS®**
USER

Europese typegoedkeur/Europäische Zulassung/European permission/Certification Européenne
E4*26R03/03*0465

CONTENTS

Foreword	46
Obligations regarding these fitting instructions	46
Proper use	46
Safety instructions – Explanation of the categories	47
Scope of delivery	48
Technical data	48
Coupling requirements	49
Safety instructions	50
Fitting the registration plate to the carrier	52
Fitting the frame holders to the carrier	52
Fitting the bike carrier to the trailer coupling	53
Mounting bicycles	56
Tilting the bike carrier, access to the luggage space	59
Dismantling the bike carrier	61
Cleaning and maintenance	61
Disposal	62
Adjustment of the quick connector	62
7/13 Plug assignment	63
Spare parts overview (Exploded drawing)	64
Spare parts overview (Table)	65

FOREWORD

The Pro-User Diamant TG bike carrier is part of the family of bike carriers manufactured by Tradekar Benelux BV.

These fitting instructions will assist you with the proper and safe fitting of the Pro-User Diamant TG bike carrier.

OBLIGATIONS REGARDING THESE FITTING INSTRUCTIONS

Every person who fits, cleans or disposes of this bike carrier must have taken note of and understood the complete contents of these fitting instructions.

Keep these fitting instructions ready to hand and safe at all times.

Hand on these fitting instructions when removing or passing on the bike carrier.

PROPER USE

The bike carrier Pro-User Diamant TG is used for the transport of max. two bicycles. In combination with the third bike adapter (article 91749), the bike carrier can be used for transporting up to three bicycles.

It must be mounted only on trailer couplings which meet the requirements specified in the chapter "Coupling requirements". The permissible carrying capacity of the bike carrier must not be exceeded under any circumstances.

Proper use also includes the observation of all information provided in these fitting instructions, and in particular the safety instructions. Any other form of use constitutes improper use, and can result in personal injury or material damage. Tradekar Benelux BV accepts no liability for damage resulting from improper use.

CONSUMER HELPDESK & SUPPORT

 +31 (0)345-470998 (Monday till Friday 8:30-12:30)



service@tradekar.com

SAFETY INSTRUCTIONS – EXPLANATION OF THE CATEGORIES

You will find in these instructions the following categories of safety instructions:



WARNING!

Personal injury possible:

Instructions under the heading **WARNING!** warn of potentially impending danger. Failure to avoid such danger may result in serious or even fatal injuries



CAUTION!

Personal injury or material damage possible:

Instructions under the heading **CAUTION!** warn of possibly impending danger. Failure to avoid such danger may result in slight or minor injuries. The product or other nearby objects may be severely damaged.



ATTENTION!

Personal injury or material damage possible:

Instructions under the heading **ATTENTION!** warn of a potentially harmful situation. Failure to avoid such situations may result in damage to the product or other nearby objects.



NOTE!

Other instructions:

Useful tip. Facilitates the operation or fitting of the product or serves for better understanding.

The safety symbol used does not replace the text of the safety instruction. Read the safety instruction and follow it exactly!

SCOPE OF DELIVERY

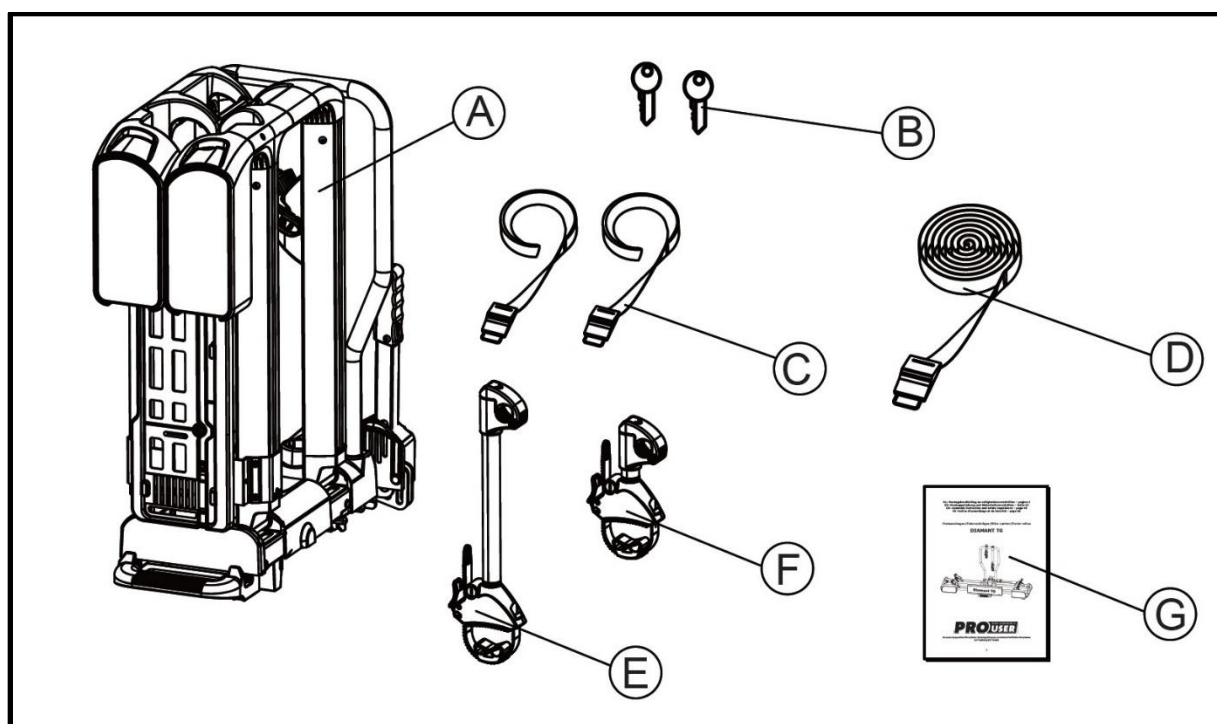

A = bike carrier

B = 2 keys

C = 2 safety straps for front wheels

D = 1 Safety strap for bicycle frame

E = frame holder long

F = frame holder short

G = assembly instruction and safety regulations

Unpack all the components and check for the presence of all parts.

TECHNICAL DATA

	Diamant TG	Diamant TG +1
Itemnumber	91748	91748 + 91749
Tiltable	Yes	Yes
Material	Steel/aluminium	Steel/aluminium
No of bicycles	2	3
Own weight	17kg	19,5kg
Carrying capacity (max.)	60kg	60kg
Wheel base bicycle (max.)	135cm	135cm(1-2) 120cm(3)
Bicycle tire width (max.)	6cm	6cm
Wheel holder distance	23cm	23cm(1-2) 14cm(2-3)

The bike carrier is suitable for the transport of two (item 91748) or three (item 91748 + 91749) bicycles at most. Please check the maximum permissible ball load. You can find it on the identification plate of the tow bar of your car (for

most cars this is 75kg). The total weight of the bike carrier with the bicycles cannot exceed the maximum permissible ball load of the tow bar.

Diamant TG:

Max. permissible ball load	Weight bike carrier	Max. carrying capacity
50kg	17kg	33kg
60kg	17kg	43kg
75kg	17kg	58kg
90kg	17kg	Max. 60kg

Diamant TG +1:

Max. permissible ball load	Weight bike carrier	Max. carrying capacity
50kg	19,5kg	30,5kg
60kg	19,5kg	40,5kg
75kg	19,5kg	55,5kg
90kg	19,5kg	Max. 60kg

COUPLING REQUIREMENTS



WARNING!

Personal injury is possible due to breakage of the trailer coupling.

The coupling could break if the bike carrier is fitted to a coupling made of a too soft material.

- Fit the bike carrier only to a coupling made of steel St52, grey cast iron GG52 or higher quality.
- Never fit the bike carrier to a coupling made of aluminium, other light metals or plastic.
- Only suitable for use on the coupling of a passenger car.
- Note the instructions of the coupling manufacture.

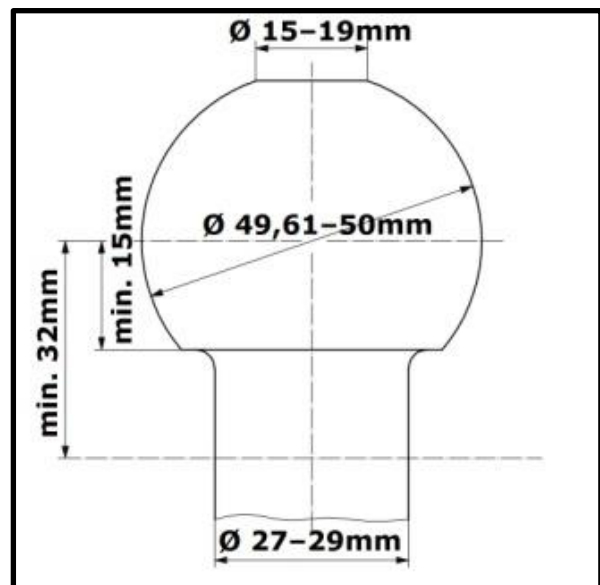

Fit the bike carrier only to trailer couplings with the following properties:

- Material: min. steel St52 or grey cast iron GG52
- D-value: >7,6 kN
- Tow ball: Ø50mm (class A-50 according EC 94/20 or ECE R55)

SAFETY INSTRUCTIONS

Follow the fitting instructions carefully. Failure to follow the instructions can lead to personal injuries and material damage.

If you are not sure about correct fitting, ask your dealer or the manufacturer for further information. Neither the manufacturer nor dealer are liable for damages which are due to improper use or fitting.

Check the bike carrier and the load regularly: you are required to do so and may be held liable in case of damage.



NOTE

The legal regulations and provisions on the transport of goods on the back of your vehicle apply when driving with a mounted bicycle carried.



WARNING!

Personal injury or material damage due to changed vehicle driving characteristics.

Driving with the bike carrier fitted will affect the driving characteristics of your vehicle.

- Adjust your speed to the new driving characteristics.
- Never exceed a speed of 130 km/h.
- Avoid sudden and jerky steering movements.
- Remember that your vehicle is longer than usual.



WARNING!

Personal injury or material damage due to overloading.

Exceeding the max. carrying capacity of the bike carrier or the permissible bearing load of the trailer coupling or the permissible overall weight can lead to serious accidents.

- Observe the information on the max. carrying capacity, permissible bearing load and permissible overall weight of your vehicle. Never exceed these specifications.



WARNING!

Personal injury or material damage due to incompletely fitted bike carrier.

Driving with a folded bike carrier can lead to accidents.

The moving parts of bike carrier constitute a source of danger if not properly fitted.

- Remove the bike carrier if it is not needed.
- Never drive with a folded bike carrier.

**WARNING!**

Personal injury or material damage due to loss of the bicycles.

Carrying bicycles without using the safety straps can lead to accidents.

- Before the start of every journey, check the correct and firm attachment of the strap around the bikes and the frame holder bracket of the carrier (see Step 8 of chapter "Mounting bicycles").
- Before the start of every journey, check the correct and firm attachment of both straps around the front wheel, and the strap around the rear wheel of the bicycle.
- Tighten the straps if necessary.
- Before the start of every journey, check that the straps are not worn or damaged.
- Worn or damaged straps must be replaced with undamaged straps before the start of the journey. The straps used must be approved by Tradekar Benelux BV.

**WARNING!**

Personal injury or material damage due to projecting parts.

Parts projecting beyond the edge of the vehicle or bike carrier can cause personal injury or material damage when driving.

- Fit only such parts which do not project beyond the edge of the vehicle or bike carrier.

**WARNING!**

Personal injury or material damage due to tarpaulins.

Tarpaulins increase the air resistance. They can become loose and fly about leading to serious accidents.

- Never use tarpaulins or covers.

**WARNING!**

Personal injury or material damage due to loss of the bicycles.

After the attachment, the carrier first settles properly into the coupling after driving several kilometres.

- Check the attachment of the carrier for secure attachment after driving several kilometres.
- Redo the attachment if it is loose.

**WARNING!**

Personal injury or material damage due to the breaking off of the bike carrier.

Driving with a mounted bike carrier over difficult terrain can lead to the carrier breaking off.

Do not use the bike carrier when driving over difficult terrain.

Only suitable for use on the hitch of a passenger car.

Drive slowly over speed bumps: max. Speed 10 km/h.

**ATTENTION!**

Material damage due to opening tailgate.

The tailgate could impact against the bike carrier and be damaged.

- Switch off electric tailgates and operate them manually.
- Fold down the bike carrier before opening the tailgate.



ATTENTION!

Material damage due to hot exhaust gases.

Damage can be caused to the bike carrier or the bicycles if the exhaust pipe is too close.

- Fit an exhaust deflector if necessary.

FITTING THE REGISTRATION PLATE TO THE BIKE CARRIER



FITTING THE FRAME HOLDERS TO THE BIKE CARRIER

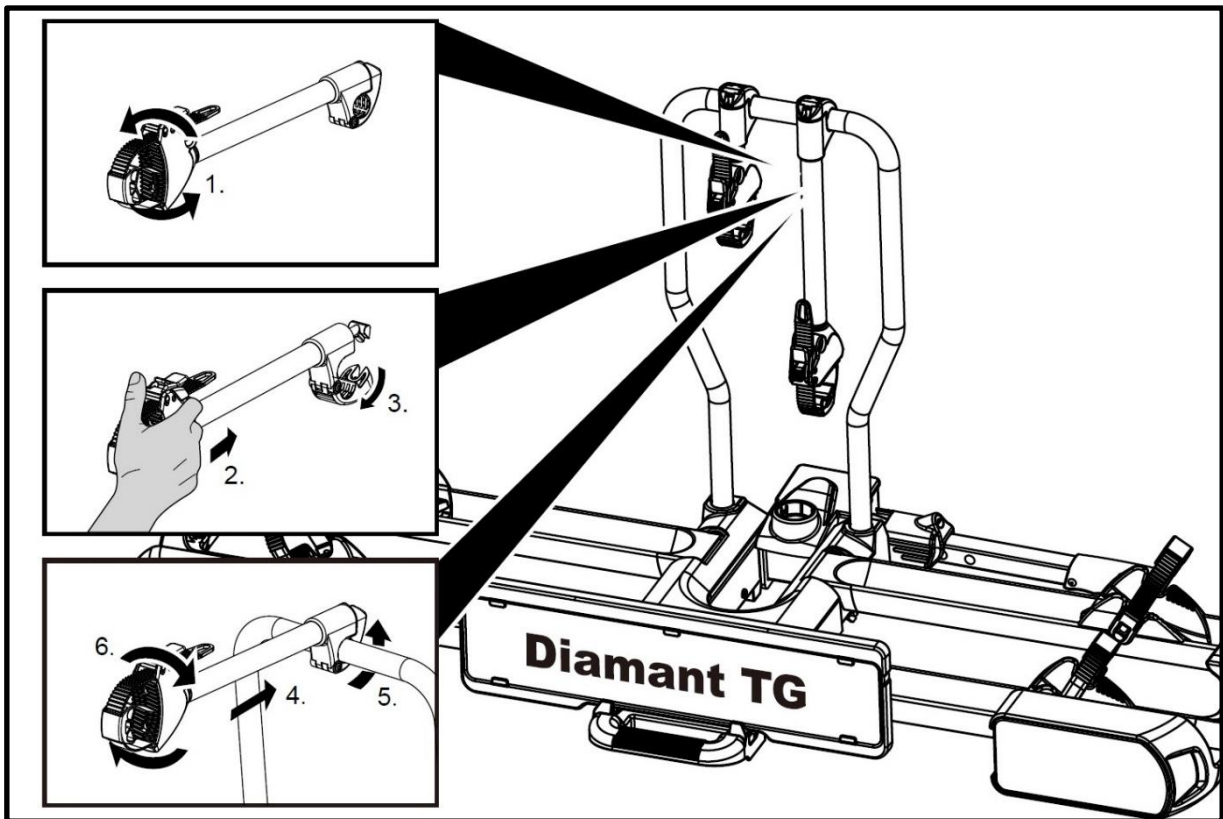

FITTING THE BIKE CARRIER TO THE TRAILER COUPLING

Park your vehicle on a level surface.
Apply the handbrake.



WARNING!

Personal injury or material damage due to damaged bike carrier.

Damage of the carrier, e.g. by bent parts, cracks or scratches, prevent the safe operation of the carrier.

- Do not fit the bike carrier if it is damaged in any way.
- Proceed as described in the chapter "Maintenance".



WARNING!

Personal injury or material damage due to loss of the bike carrier during the journey.

A faulty or defective connection between the bike carrier and trailer coupling can lead to the detachment of the bike carrier.

- Replace the trailer coupling if it is damaged.
- Clean the trailer coupling of dirt, dust and grease.



NOTE

There is often a layer of paint on the coupling ball. For the best possible attachment of the bike carrier, this paint coating should be carefully removed. Note the instructions of the coupling manufacturer.

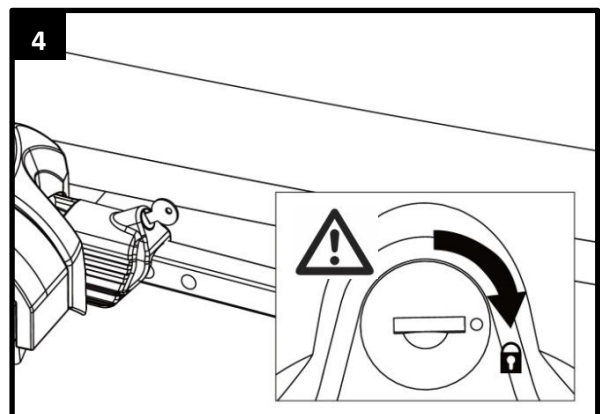
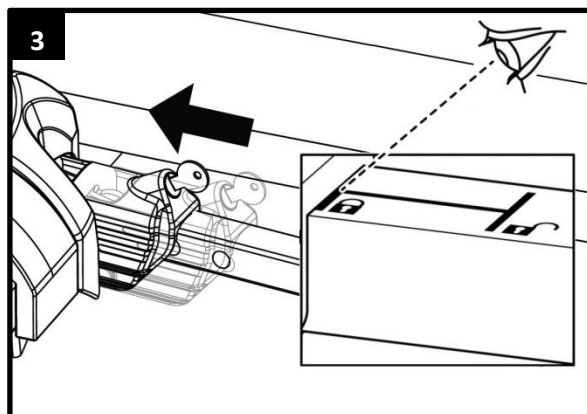
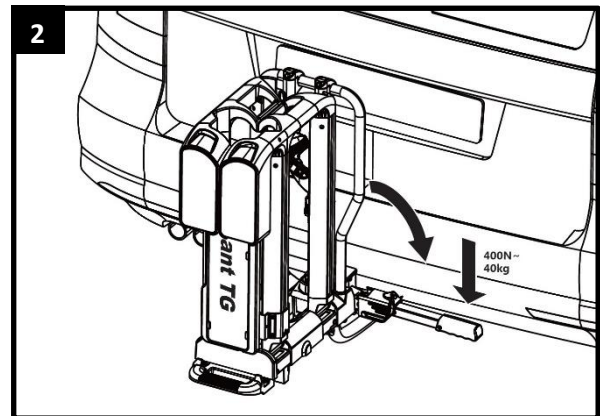
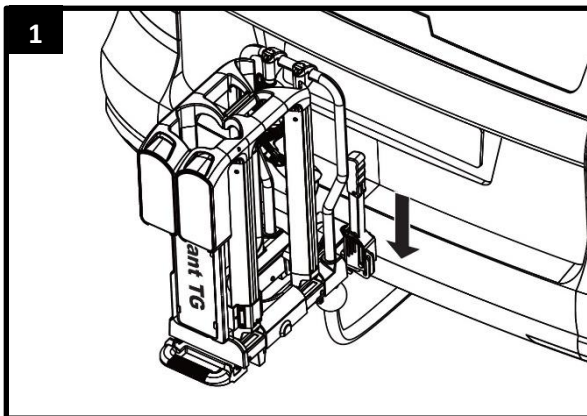
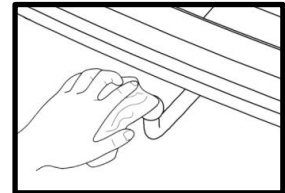



WARNING!

Personal injury or material damage due to unsecure bike carrier.
If the lever is not secured by locking, the bike carrier could become detached from the vehicle during the journey

- Lock the bike carrier.
- Check that you have locked the lever and removed the key. Locking the bike carrier also prevents its possible loss by theft.



WARNING!

Personal injury or material damage due to loss of the bike carrier during the journey.

A loose connection between the bike carrier and trailer coupling can lead to detachment of the bike carrier.

- Check the bike carrier for secure attachment.
- Repeat steps 1 to 4 in the event of a loose connection. If this brings about no improvement, the quick connector may need to be adjusted, see chapter "Adjustment of the quick connector".

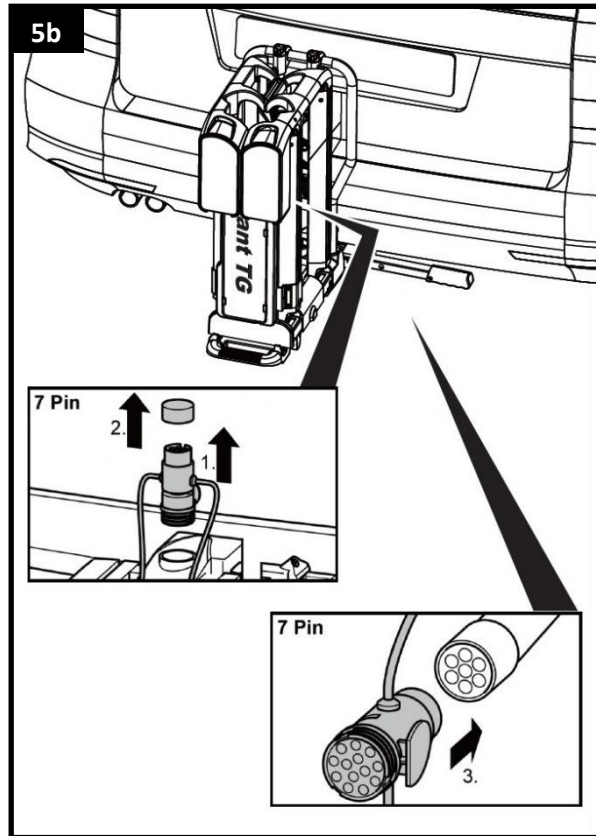
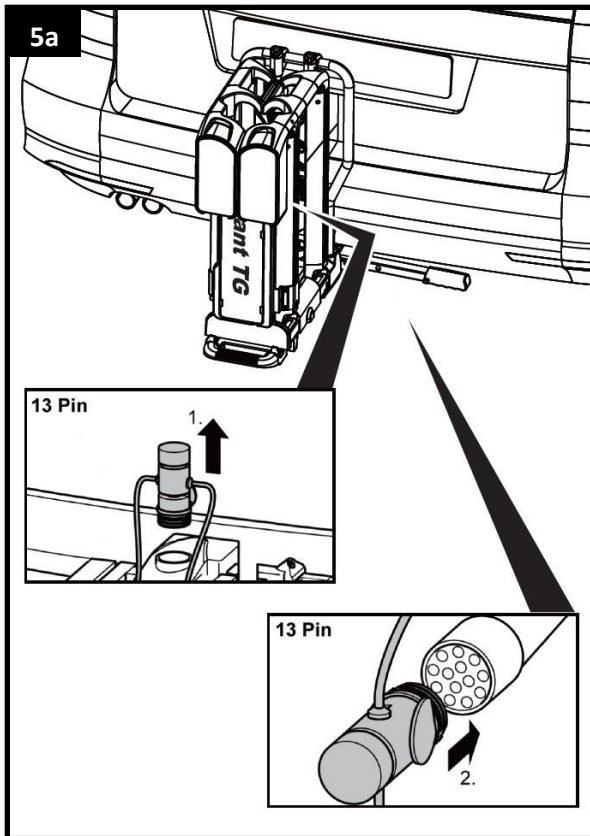

**WARNING!**

Personal injury due to not being seen by other road-users.

Driving with a defective lighting system can lead to accidents.

- Check the correct operation of the lighting system before the start of every journey.
- Replace any defective bulbs.
- Check the connection between the plug and coupling.

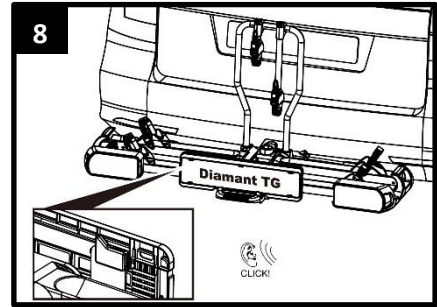
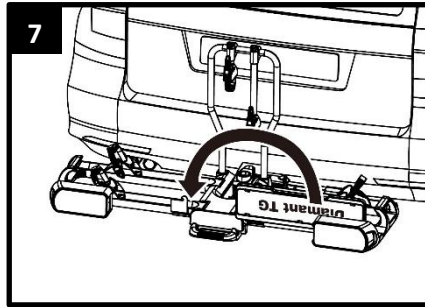
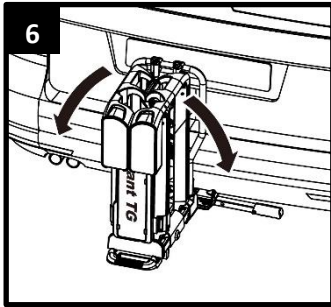
**WARNING!**

Personal injury or material damage due to unsecure registration plate holder.

If the registration plate holder is not secured by the locking bolt, it could become detached during the journey.

- Fold down the registration plate holder until it is heard to engage.
- Release the locking bolt and allow it to engage in the hole in the registration plate holder.

MOUNTING BICYCLES



ATTENTION!

Personal injury or material damage possible due to loose parts.

Improperly tightened parts on the bicycles can become loose during the journey.

- Remove all parts not firmly attached to the bicycle, such as e-bike battery, bicycle pump, bicycle bag, bicycle crate, bicycle basket, child seat, bottle or navigation device.



NOTE

In order to improve the driving characteristics of your vehicle, mount the heavier bicycle first. If carrying only one bicycle, this should be mounted in the rail closest to the rear of the vehicle.



NOTE

The frame holders are flexible to place on the U-tube, and are also flexible to place on your bicycle. Try the first time which position in your situation works best (and most stable affirmative is). It is important to place the frame holder as high as possible, giving maximum stability.

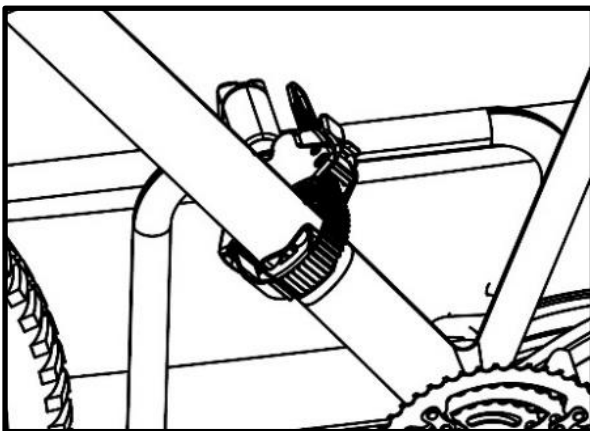
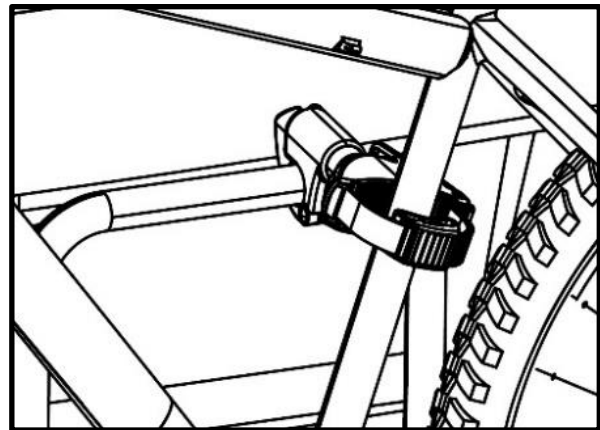
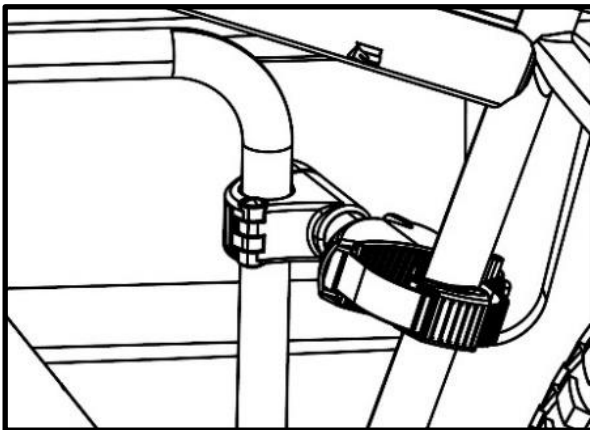

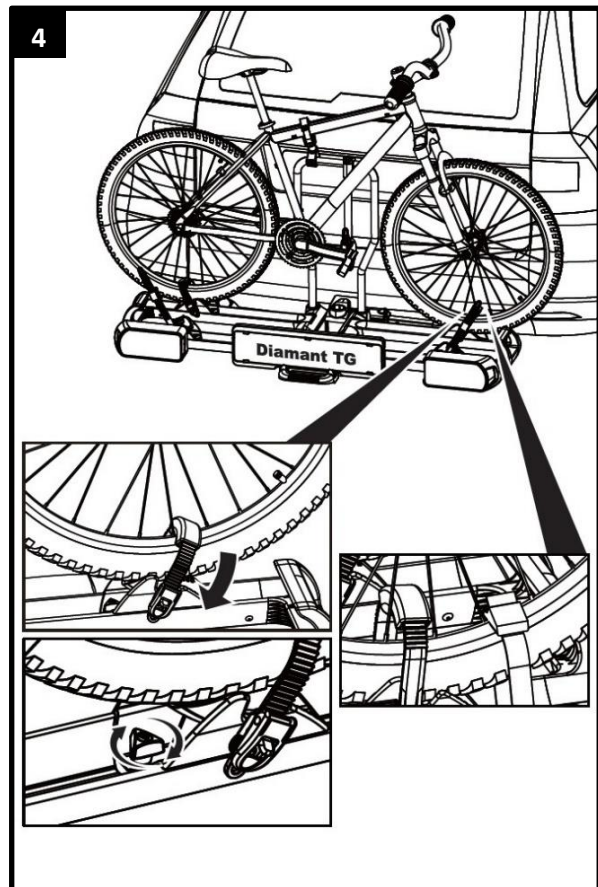
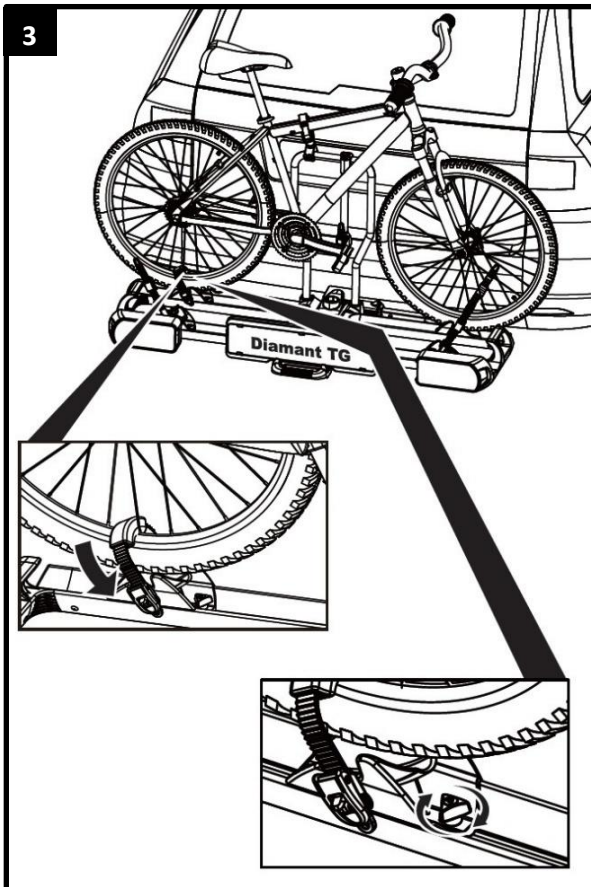
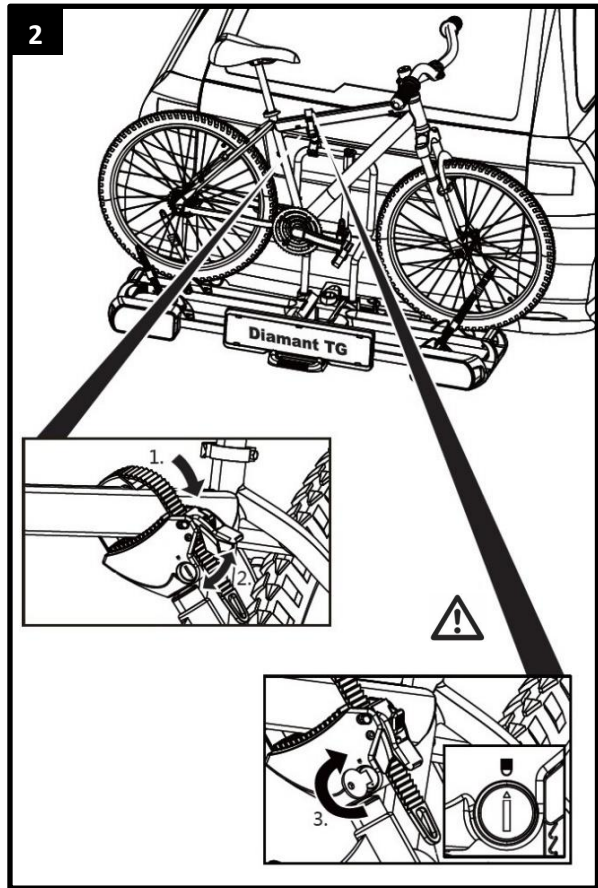
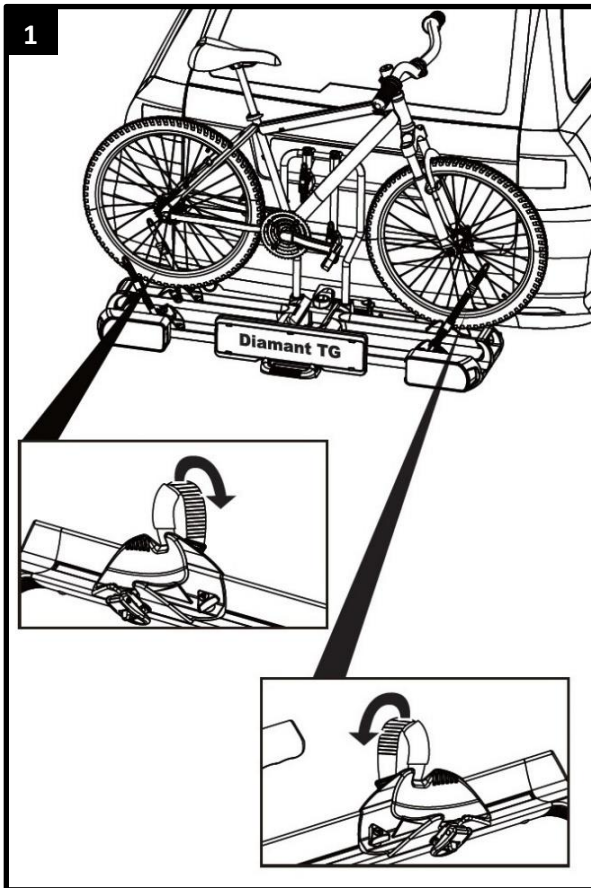

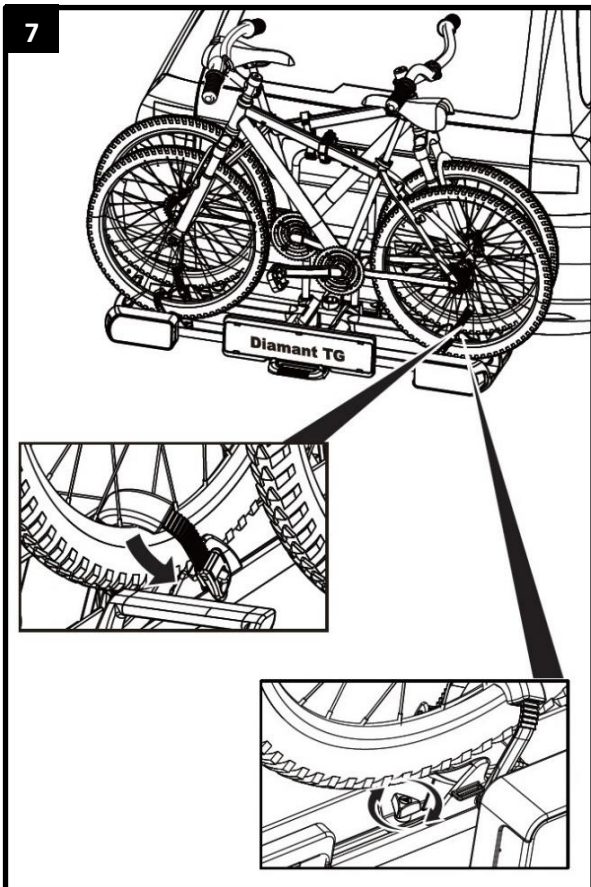
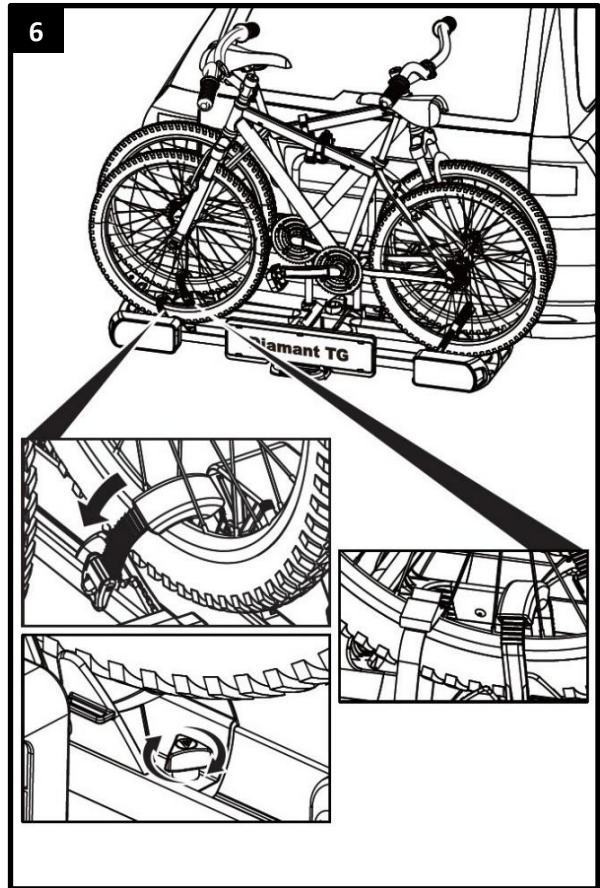
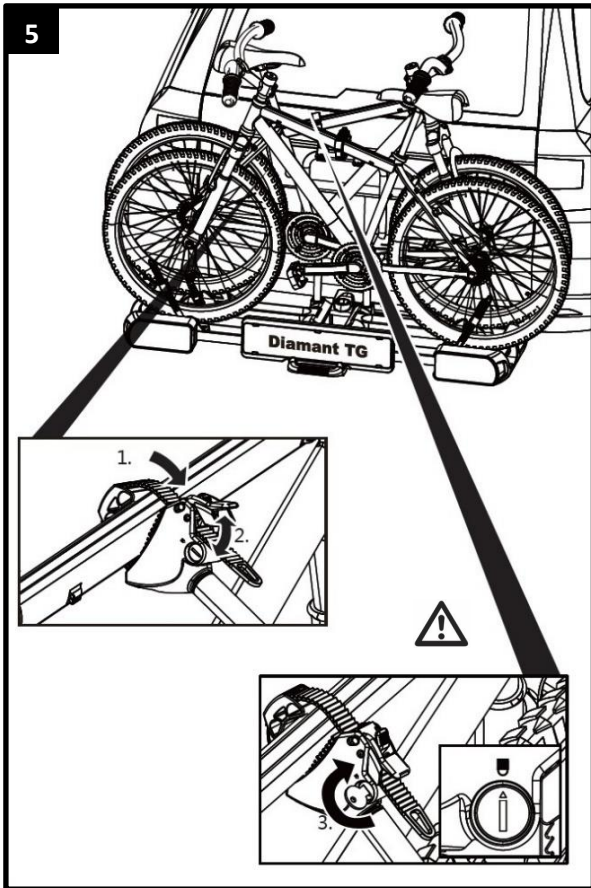



WARNING!

Personal injury or material damage due to loss of the bicycles.

Carrying bicycles without using the safety straps can lead to accidents.

- Before the start of every journey, check the correct and firm attachment of the strap around the bikes and the Frame holder bracket of the carrier (see step 8).
- Before the start of every journey, check the correct and firm attachment of both straps around the front wheel, and the strap around the rear wheel of the bicycle.
- Tighten the straps if necessary.
- Before the start of every journey, check that the straps are not worn or damaged.
- Worn or damaged straps must be replaced with undamaged straps before the start of the journey. The straps used must be approved by Tradekar Benelux BV.

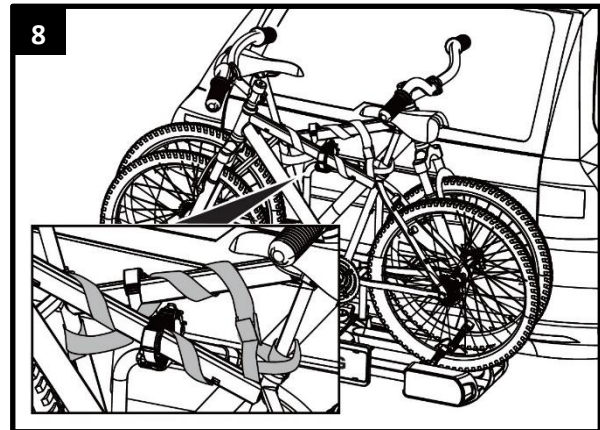

WARNING!

Personal injury or material damage due to loss of a bicycle during the journey.

A loose connection between the bike carrier and bicycle can lead to detachment of the connection and loss of the bicycle.

- Check the bicycles for secure and complete attachment.
- Repeat steps 1 to 8 of this chapter in the event of a loose connection.

TILTING THE BIKE CARRIER, ACCESS TO THE LUGGAGE SPACE



ATTENTION!

Material damage due to opening tailgate.

The tailgate could impact against the bike carrier and be damaged.

- Switch off electric tailgates and operate them manually.
- Fold down the bike carrier before opening the tailgate.

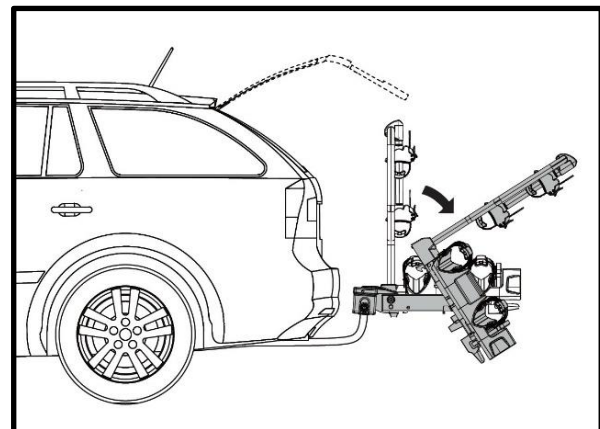

**CAUTION!**

Personal injury or material damage due to sudden folding down of the carrier.

Body parts or objects under or in front of the carrier when it is folded down may be trapped.

- Make sure that there is nothing under the carrier.
- Keep all body parts, and particularly your head, clear, and maintain a suitable safety distance.
- Hold the carrier by the bicycle when folding it down. With your foot loosen the locking device and then tilt the carrier downward with your hand (see fig. 1)

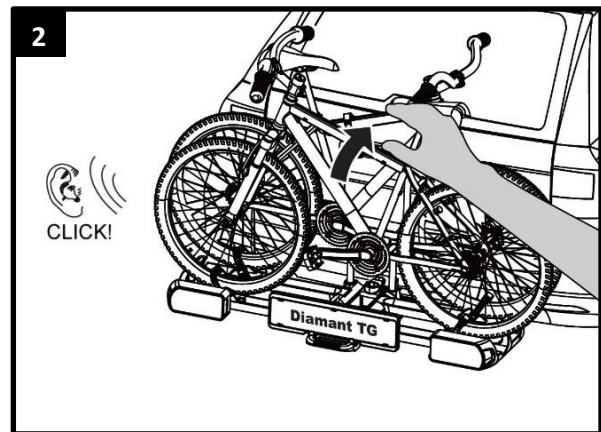
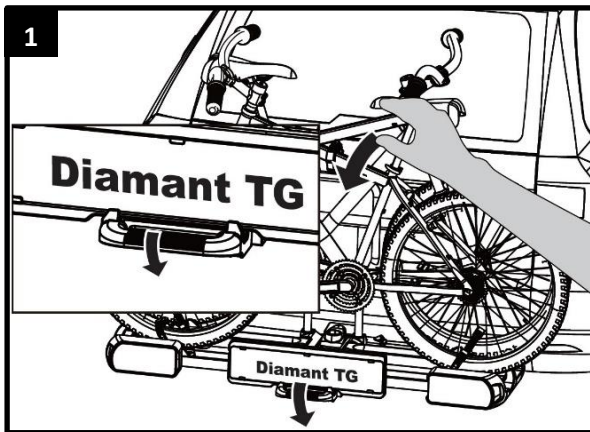
**CAUTION!**

Personal injury or material damage possible when folding up the carrier.

Body parts or objects between the carrier and the vehicle when it is folded up may be trapped.

- Make sure that there is nothing between the carrier and the vehicle.
- Remove any objects between the carrier and the vehicle.

**WARNING!**

Personal injury or material damage possible due to loss of the bike carrier during the journey.

A bike carrier which is not folded up can result in detachment of the carrier or the coupling.

- Fold the carrier up before the start of the journey (see fig. 2 of this chapter).
- Check that the bike carrier is properly secured in this position.

DISMANTLING THE BIKE CARRIER

To dismantle the bike carrier, proceed in the reverse order to fitting:

- Unlock the license plate holder and turn it to the storage position.
- Fold the bike carrier together.
- Remove lighting connector from the car.
- Release the quick-release lever and pull the wearer of the device.

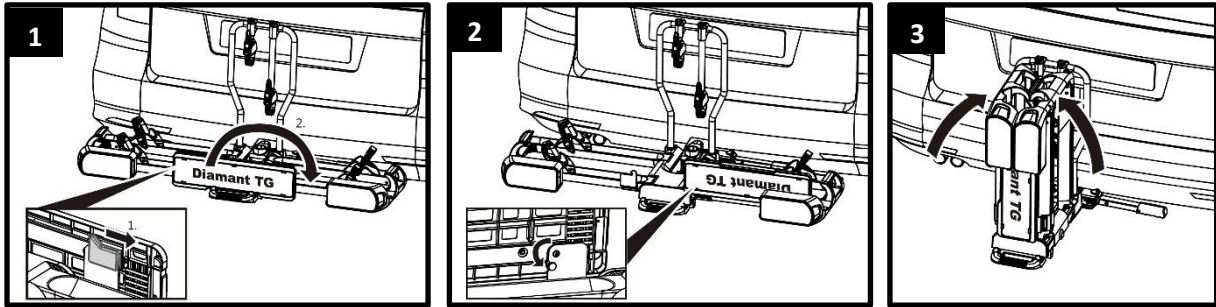

The ingenious folding system makes it really easy to carry and to store.

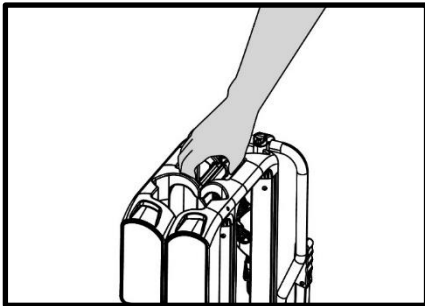

CLEANING AND MAINTANANCE

Under normal conditions and use, the bike carrier only requires cleaning, and is otherwise maintenance free.

The bike carrier can be cleaned with a mild cleaning agent, with warm water and/or a soft cloth. First remove any coarse dirt and dust.

Do not use any solvents or similar cleaning agents, since these can damage the bike carrier.

Leave the bike carrier to dry on its own. Do not use any electrical driers or other heating equipment to speed up the drying process.

Clean the bike carrier regularly when used in coastal areas or in winter conditions in order to wash off any salt and prolong the service life of the bike carrier.

Store the bike carrier in a dry and protected area when not used for extended periods (e.g. over winter) in order to prolong the service life of the bike carrier. Check the bike carrier for wear before the start of every journey.

Defective parts and straps must be replaced.

The steel parts of the bike carrier are protected in the works against corrosion by a powder coating. If this paint coating is damaged, please have the damage rectified professionally as soon as possible.

Please refer to our customer service for the replacement of parts.

Any modification of original parts and materials or the construction of bike carrier can adversely affect its safety and serviceability.

DISPOSAL

Local regulations must be observed for the disposal of the product.

The packaging should also be sorted by type and disposed of in the relevant collection containers.

Further information is available from your communal disposal point.

ADJUSTMENT OF THE QUICK CONNECTOR

Carry out this maintenance operation only if the bike carrier cannot be fitted firmly to the trailer coupling, as described in the chapter "*Fitting the bike carrier to the trailer coupling*".

Remove the bike carrier from the trailer coupling, as described under "*Dismantling the bike carrier*".

- Loosen the locking nut slightly (fig. 1).
- Screw in the setting screw one quarter of a turn (fig. 1).
- Tighten the locking nut (fig. 2)
- Check whether the carrier is now firmly seated on the trailer coupling, as described under "*Fitting the bike carrier to the trailer coupling*". If not, repeat the above steps.

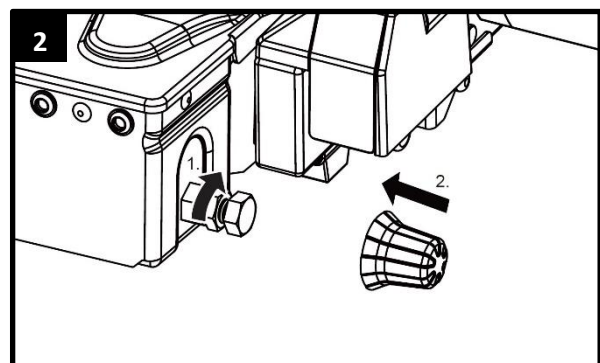
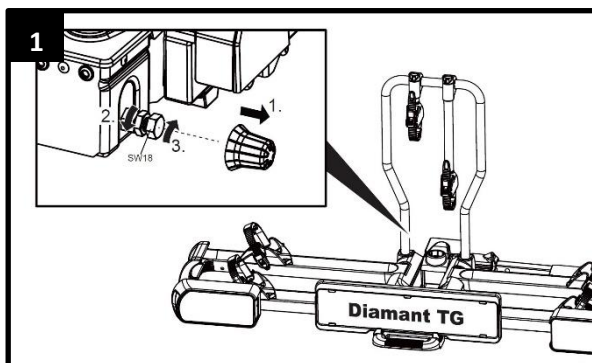

7/13 PIN CONNECTOR

This bike carrier is equipped with a lighting system. This system can be connected to the tow bar power socket of your car. Seeing that there are different kinds of sockets that require different kinds of plugs, this carrier comes with the usual 7pin plug and the 13pin plug (Jaeger). As a result, the carrier can be used with any tow bar!

Both plugs are in one housing. Please cover the plug you don't use with the supplied cover.

This information is only for the retrofitting by a specialised dealer. A retrofitting by non trained persons is not permitted.

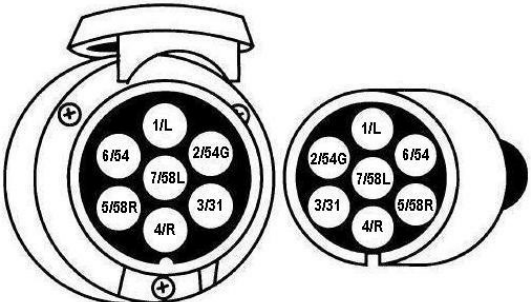
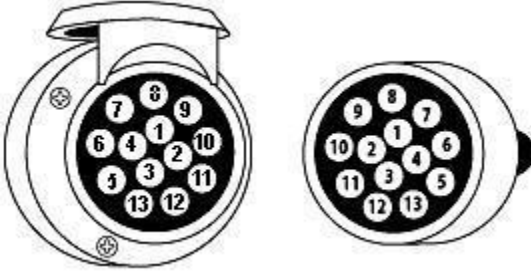
<p>Universal system 7 pin</p> 	<p>1/L 2/54G 3/31 4/R 5/58R 6/54 7/58L</p>	<p>Indicator left Rear fog light Ground Indicator right Rear light right Stop lights Rear light left</p> <p><i>The reversing light is not working via the 7-pin plug!</i></p>	<p>yellow blue white green brown red black</p>
<p>Jaeger system 13 pin (DIN 72.570)</p> 	<p>1 2 3 4 5 6 7 8 9 10 11 12 13</p>	<p>Indicator left Rear fog light Ground Indicator right Rear light right Stop lights Rear light left Reversing light <i>Not used</i> <i>Not used</i> <i>Not used</i> Ground <i>Not used</i></p>	<p>yellow blue white green brown red black gray</p>

EXPLODED VIEW

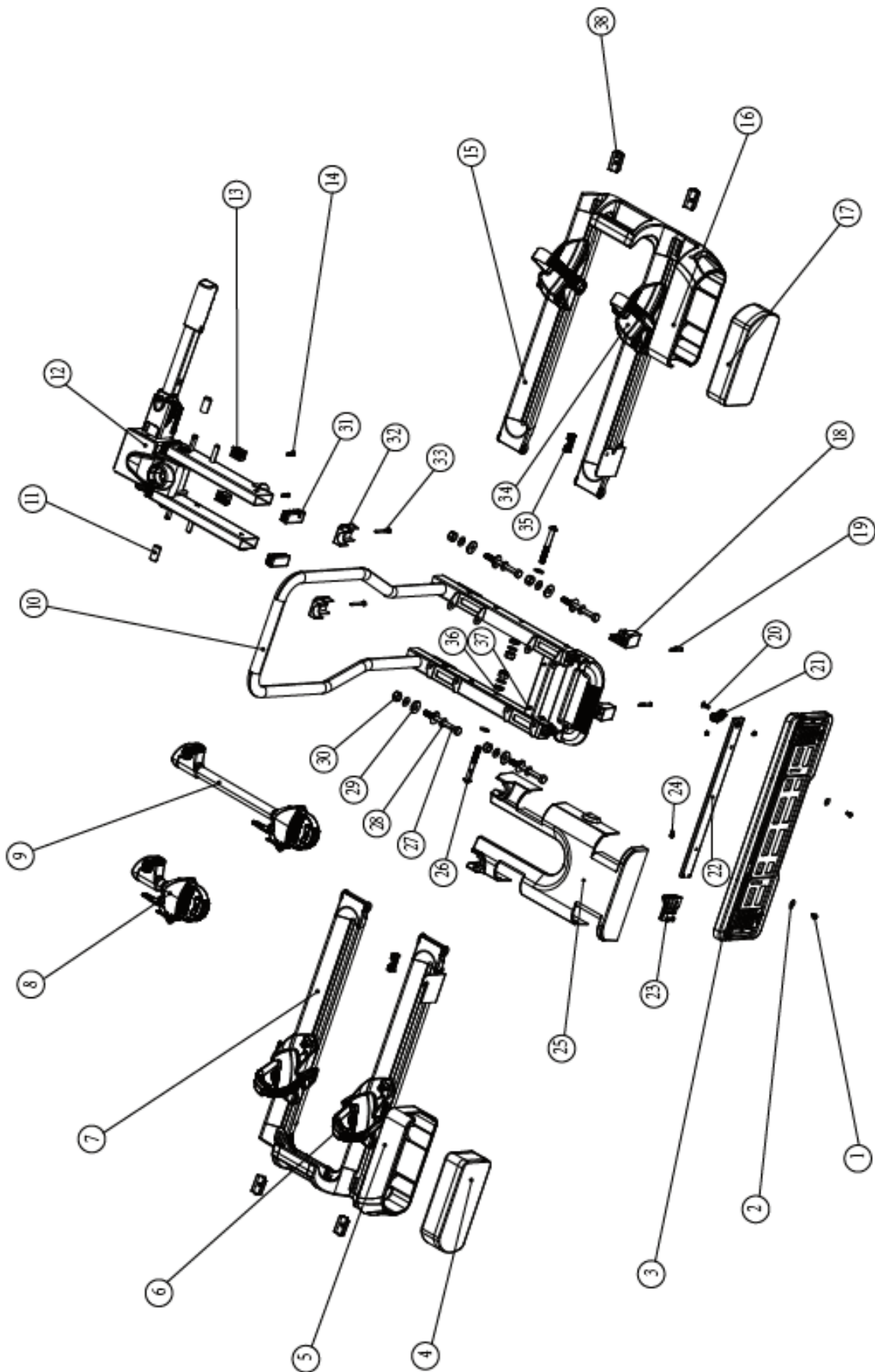

PART LIST

Pos nr.	Description	QTY	Remark
1	Inner-socket bolt	2	M5x10
2	Washer	8	M5
3	License plate holder	1	
4	Rearlight left	1	
5	Lamp protector (left)	1	
6	Plastic wheel stopper left	2	
7	Aluminium wheel holder frame left	1	
8	Frame holder short	1	
9	Frame holder long	1	
10	Mainframe with U-tube	1	
11	Plastic cover	2	
12	Mainframe with quick connector	1	
13	Plastic support (short)	2	
14	Inner-socket bolt	2	M5x20
15	Aluminium wheel holder frame right	1	
16	Lamp protector (right)	1	
17	Rearlight right	1	
18	Plastic support (long)	2	
19	Inner-socket bolt	2	M5x35
20	Bolt	1	
21	Plastic License plate holder clip	1	
22	License plate holder fixation tube	1	
23	License plate holder locking	1	
24	Nylon nut		M5
25	Plastic cover	1	
26	Bolt	2	M10x80
27	Bolt	4	M10x100
28	Washer	12	M10
29	Plastic washer	8	
30	Nylon nut	6	M10
31	Plastic cover	4	60x25
32	Plastic cover	2	
33	Screw	2	ST4.8x50
34	Plastic wheel stopper right	2	
35	Rubber cover	2	
36	Plastic washer	2	
37	Screw	2	ST4.8x40
38	Plastic cover wheel stopper	4	

© Tradekar 91748/21A

PRO BIKE CARRIERS®
USER

Tradekar Benelux BV

Ohmweg 1
4104 BM CULEMBORG
The Netherlands

+31 (0)345-470990
info@tradekar.com
www.pro-user.eu

